



0518



**Brief Description**

The Peppers CROCLOCK<sup>®</sup> CR-C\*\* type Compound-filled cable gland is for outdoor use in the appropriate Hazardous Areas with pliable wire armour, steel wire armour, steel tape, braided and screened cable of any construction. A variant giving electrical continuity to a lead sheath is available. It gives environmental protection to IP68 and Deluge. A termination suitable for EMC protection can be made using armoured cables.

**Warning**

PLEASE STUDY CAREFULLY BOTH PAGES OF THESE INSTRUCTIONS BEFORE INSTALLATION. These glands should not be used in any application other than those mentioned here or in our Data Sheets, unless Peppers states in writing that the product is suitable for such application. Peppers can take no responsibility for any damage, injury or other consequential loss caused where the glands are not installed or used according to these instructions. This leaflet is not intended to advise on the selection of cable glands. Further guidance can be found in the standards listed overleaf.

**STEP-BY-STEP FITTING INSTRUCTIONS**

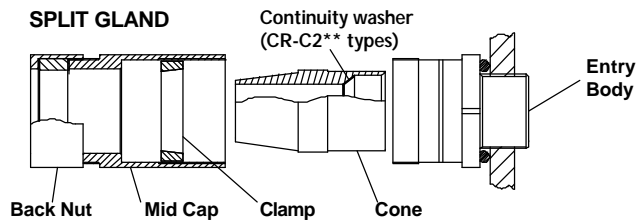

Gland size	4	11
	Armour length	Compound length
16 - 25	25mm	40mm
32 - 40	30mm	45mm
50S - 75	32mm	50mm
80 - 100	50mm	60mm

**CABLE PREPARATION**

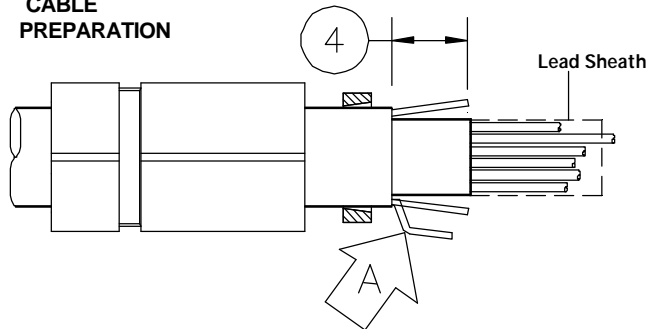

**COMPOUND PACKING**

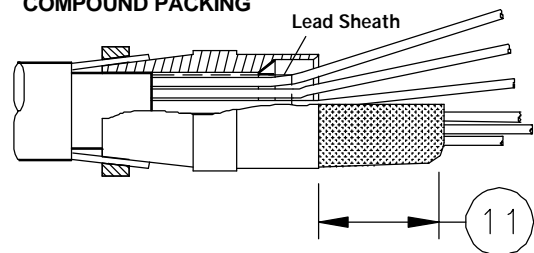

**COMPOUND EXTRUSION**

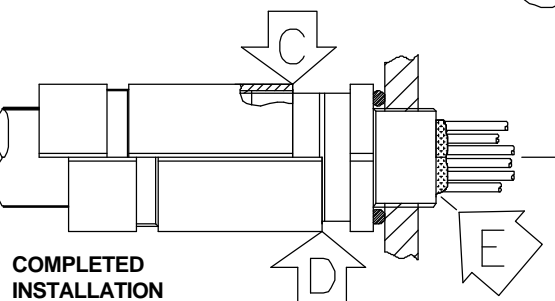
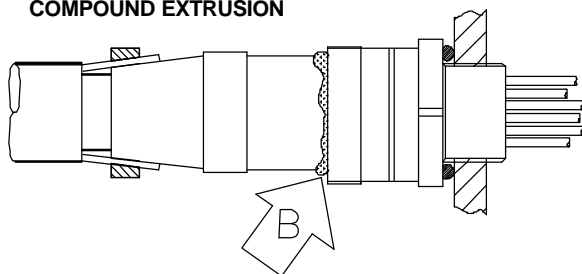

**STEP-BY-STEP FITTING INSTRUCTIONS**

- 1 Split gland as shown
- 2 Fit Entry Body. Hand-tighten, then using wrench tighten a further 1/2 turn. DO NOT EXCEED MAX TORQUE FOR ENCLOSURE
- 3 Slide Back Nut, Mid Cap and Clamp onto cable as shown
- 4 **CABLE PREPARATION**  
Strip off outer jacket, length to suit installation  
**For armoured cable:-**  
**A** Cut armour. For approximate exposed lengths see Table 1 column 4  
**B** Where sheath sizes are near minimum, form armour to facilitate clamping (arrow A)  
**For all cables:-**  
**C** Remove inner sheath, length to suit installation. Lead sheath must be cut to push through the continuity washer. Remove protective foils, and any cords/fillers from around and between the cores. Take care not to cut the insulating sleeves of the cores. Pigtail and sleeve screens to be passed through compound
- 5 Slide Cone onto inner sheath and under armour. Any lead sheath is now pushed through the continuity washer. Slide Clamp onto exposed armour
- 6 Insert cable through Entry Body and engage Cone in Entry Body
- 7 To clamp armour onto Cone, hand-tighten Mid Cap to Entry Body, then using wrench tighten a further 1 turn
- 8 Unscrew Mid Cap to visually check armour is securely clamped. Pull out cable and Cone

**HEALTH AND SAFETY WARNING** The resin used in the compound can cause eye and skin irritation. For your personal protection, wear the gloves supplied while mixing and applying. The uncured compound should not be allowed to come into contact with foodstuffs.  
**A COMPREHENSIVE SAFETY DATA SHEET PROVIDED BY THE COMPOUND MANUFACTURER IS AVAILABLE ON REQUEST**

**CR-C\*\* Compound-Filled Cable Gland featuring CROCLOCK® - ASSEMBLY INSTRUCTIONS FOR SAFE USE**

- 9 Check compound has not passed its "Use By" date. Installation at temperatures below 10°C should be avoided. Trim any hardened pieces from ends of stick
- 10 Mix the compound by rolling, folding and breaking. Ease mixing by cutting large sticks in half. Fully mixed compound has a uniform yellow colour with no streaks
- 11 Support the cable and rear gland assembly. With unarmoured cable, hold Cone and cable roughly concentric. Splay out the cores. Starting at the middle, pack small amounts of rolled-out compound between the cores. Re-straighten each core and work outwards until all gaps are filled. Bundle the cores with cord or tape so they are not disturbed. Pack around the outside of the outer cores to fill the Cone cup. Build up compound around the outside of the cores with a slight taper and to approximate compound length shown in diagram and Table 1 column 11
- 12 Pass cores through & push compound into Entry Body until Cone engages. Remove squeezed out compound at arrow B. Screw Mid Cap 7 full turns onto Entry Body for thickest armour (arrow C). For tape armours/braids do not screw past groove (sizes 16 & 20S: do not screw past painted area) (arrow D). Ensure that compound emerges at entry thread (arrow E).
- 13 Clean off excess compound from Entry Body to allow withdrawal when cured (arrow E). Cores may be disturbed after 1 hour. Leave to cure for 4 hours when working at 21°C.
- 14 To release the joint for inspection, unscrew Mid Cap. Using wrench on Cone, release joint & pull out
- 15 Hand-tighten Mid Cap to remake joint. Then refer to table below and tighten using wrench to the given amount. Hold Mid Cap with wrench and tighten Back Nut onto cable. Ensure seal makes full contact with cable sheath, then tighten Back Nut 1 extra turn.
- 16 The equipment should not be energised until the compound has been left to cure for at least 4 hours when working at 21°C. See chart 'Energising Time vs. Temperature' for further guidance

**Wrench tightening information (Instruction 15), cable sizes (mm), construction and armour acceptance (mm)**

Gland Size	Tighten Mid Cap using wrench	Max dia over cores	Max No of Cores	Inner Sheath	Outer Sheath		Reduced Bore		Armour size Universal
				Max	Min	Max	Min	Max	
16	¼turn	9.0	7	11.7	9.0	13.5	6.7	10.3	0.15 -1.25
20S	¼turn	10.4	8	11.7	11.5	16.0	9.4	12.5	0.15 -1.25
20	¼turn	12.5	14	14.0	15.5	21.1	12.0	17.6	0.15 -1.25
25	¼turn	17.8	25	20.0	20.3	27.4	16.8	23.9	0.15 -1.6
32	¼turn	23.5	50	26.3	26.7	34.0	23.2	30.5	0.15 -2.0
40	¼turn	28.8	80	32.2	33.0	40.6	28.6	36.2	0.2 -2.0
50S	¼turn	34.2	100	38.2	39.4	46.7	34.8	42.4	0.2 -2.5
50	¼turn	39.4	100	44.1	45.7	53.2	41.1	48.5	0.2 -2.5
63S	¼turn	44.8	120	50.1	52.1	59.5	47.5	54.8	0.3 -2.5
63	¼turn	50.0	120	56.0	58.4	65.8	53.8	61.2	0.3 -2.5
75S	¼turn	55.4	140	62.0	64.8	72.2	60.2	68.0	0.3 -2.5
75	¼turn	60.8	140	68.0	71.1	78.0	66.5	73.4	0.3 -2.5
80	¼turn	64.4	160	72.0	77.0	84.0	N/A	N/A	0.45 -3.15
85	¾turn	69.8	180	78.0	79.6	90.0	75.0	85.4	0.45 -3.15
90	¾turn	75.1	200	84.0	88.0	96.0	N/A	N/A	0.45 -3.15
100	¾turn	80.5	220	90.0	92.0	102.0	87.4	97.4	0.45 -3.15

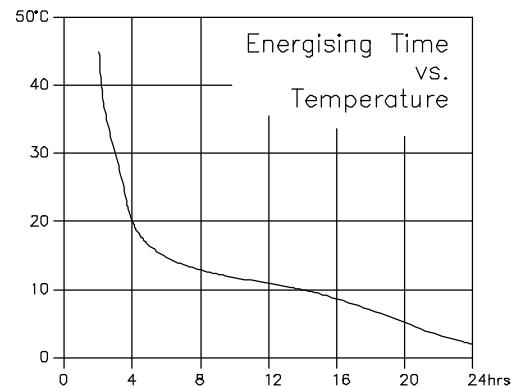

**Installation Guidance**

Point	Advice
1	<ul style="list-style-type: none"> <li>◆ BS EN 60079-10:2003 Classification of Hazardous Areas</li> <li>◆ BS EN 60079-14:1997 Electrical Installations in hazardous areas (other than mines)</li> <li>◆ BS 6121, Part 5:1993 Selection, Installation and Maintenance of Cable Glands</li> </ul>
2	Installation should only be carried out by a competent electrician, skilled in cable gland installation.
3	<b>NO INSTALLATION SHOULD BE CARRIED OUT UNDER LIVE CONDITIONS.</b>
4	To maintain Ingress Protection ratings above IP54, use IP washers or O-rings for parallel threads. For taper threads use thread sealant.
5	The surface of the enclosure should be sufficiently flat and rigid to make both the IP joint, and (where necessary) a suitable earth contact. Relieve enclosure entry thread holes no more than 1.5mm above thread diameter.
6	Once installed do not dismantle except for occasional inspection. The gland is not serviceable and spare parts are not supplied.
7	Parts are not interchangeable with any other design. If manufacturers' parts are mixed, certification will be invalidated.

**Limitations on Usage.** Be sure your installation complies with the following:-

Feature	Comment
Enclosure entry thread	The female thread in the enclosure must comply with clause 5.3 of EN 50018:2000, or clause 5.3 of IEC 79-1, as appropriate. Do not damage threads on assembly. Check the number of full turns of thread engaged is at least 5

**Interpretation of Markings.** Markings on the outside of this gland carry the following meanings: -

Cable Gland Type & Size	
<b>CR</b>	Product range CROCLOCK® (with one universal clamp ring)
<b>C</b>	Universal barrier gland Seal Type :- Epoxy resin-based cement (Temp range -60°C to +85°C)
<b>2</b>	Lead sheath continuity option only
<b>B</b>	Main component material : B = brass; S = stainless steel
<b>R</b>	Optional reduced bore outer seal (red silicone rubber).
<b>20S</b>	Gland size
<b>IP68</b>	Ingress Protection code
<b>PG16</b>	Entry thread type and size
<b>Year Code:</b>	XX

ATEX (EU Directive 94/9/EC) Markings	
<b>Ex</b>	EU Explosive Atmosphere Symbol
<b>I M2</b>	Mining use, Category M2
<b>II 2</b>	Surface use, Category 2, Zones 1, 2, 21 and 22
<b>G</b>	For use with potentially explosive gas mixtures
<b>D</b>	For use with combustible dusts

CENELEC Certification Markings	
<b>E</b>	Conformity with European Standard
<b>Ex</b>	Explosion Protection symbol
<b>d</b>	Protection type code : d = Flameproof
<b>I &amp; IIC</b>	Gas Group Code suitable for Group I (e.g. methane) & Group IIC (e.g. hydrogen) ignitable gas/air mixtures, and also Groups IIB and IIA
<b>SIRA</b>	Certifying Body
<b>03</b>	Year of Certification
<b>ATEX</b>	Certified compliant with ATEX Directive 94/9/EC
<b>1479</b>	Certificate Serial Number
<b>X</b>	<b>Special Conditions for Safe Use :-</b> These glands must not be used with enclosures where the temperature at the point of mounting exceeds -60°C to +85°C